

General Construction

The *Topflo*® HRPVX-EC range of vertical heat recovery units is of a standard construction of a 25mm thick double skinned case. The case has inner and outer skins of span-gled galvanized sheet steel and is filled with 45kg/m³ density mineral wool slab.

Access is via removable and hinged front panels.

Inspection Upon Receipt Of Goods

Immediately upon receipt of any goods, a careful inspection should be undertaken to ensure neither damage nor missing parts. Particular attention should be paid to the fan impeller, coil connections and casework.

In the event of such damage or loss having occurred, inform AVT (01264 356415) WITHIN 3 WORKING DAYS of the delivery date, giving the serial number which can be found on the name-plate. After this period we will be unable to entertain any claim for loss or damage.

Handling

Units must be handled with care to avoid damage, particularly units being craned into position. A spreader bar should be employed to prevent damage to the top of the unit.

Installation

When installing our equipment, the following must be observed:

Safety: It is the responsibility of the installer to ensure that the installation complies with the legal regulations and the current **HEALTH AND SAFETY AT WORK ACT**.

Ambient Temperatures: The range of units covered by this manual are designed for use in an environment where the ambient air temperature is unlikely to exceed 40°C.

Mounting / Positioning: These units must be mounted in the horizontal plane and on a completely flat base.

Duct Connections: Adjoining ductwork should always be independently supported to avoid undue stress on the unit casing. Impellers are statically and dynamically balanced, and anti-vibration mounts and flexible flanges are available to suit.

Access: All units are designed with easily removable components for maintenance purposes. Sufficient room should be allowed adjacent to the unit to allow components to be withdrawn.

Electrical Wiring

Electrical supply must be fully isolated before attempting any work on the unit.

All wiring should be carried out by a competent electrician and should comply fully with the current I.E.E. Wiring Regulations.

The electrical supply must be as stated on the nameplate.

When the wiring is complete, check for free and correct rotation of the fan impeller

Heat Recovery

Units fitted with Counter Flow Plate Heat Exchangers **MUST NOT** have the supply and extract fans running independently from each other as this will cause damage to the heat exchanger module.

Maintenance

3 Monthly: Filters should be inspected and if found to be heavily soiled, replaced.

6 Monthly: The fan impeller should be carefully cleaned with a brush. This will prevent the impeller from becoming unduly dirty and unbalanced. Damper cogs, blades and frames should be cleaned and lubricated with a PTFE or silicone oil aerosol lubricant.

12 Monthly: The security and integrity of all fastenings should be checked, particularly the motor mounting frame.

Heat Exchanger

Heat exchangers have no moving parts, therefore only minimal maintenance is required. Periodically inspect heat exchange matrix for any debris, dust or dirt build up. If found it should be removed by one of the following methods.

Superficial dust or debris can be removed from the surface of the heat exchange matrix by gently brushing with a soft long-haired brush. Loosened debris can then be flushed through with warm water or vacuumed from the surface of the matrix.

Stubborn deposits can be removed by using a low-pressure washer with an approved detergent solution. The solution temperature should not exceed 50°C when using any pressure device.

The heat exchanger should **NOT** be steam cleaned under any circumstances

Spares

Spare parts or direct replacements are normally held in stock and are available for a period of up to 10 years from installation.

Any spare part can be ordered by contacting AVT (01264 356415) and quoting the unit serial number which can be found on the nameplate.

A complete list of recommended spares can be issued upon request.

Trapping

Correct trapping of the condensate line is essential to prevent flooding or liquid splashing back into the drain pan

NEGATIVE PRESSURE DRAIN TRAP FOR DRAW THROUGH COIL

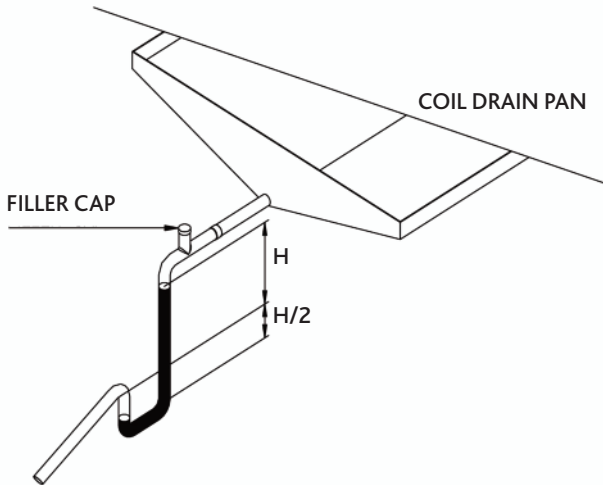

DIMENSION 'H' = TOTAL STATIC PRESSURE MM WG + 25MM MINIMUM

Do not allow trap to dry out: include adjacent water filling point

Damper Actuator Wiring – If HRCP* Controller Is Not Fitted

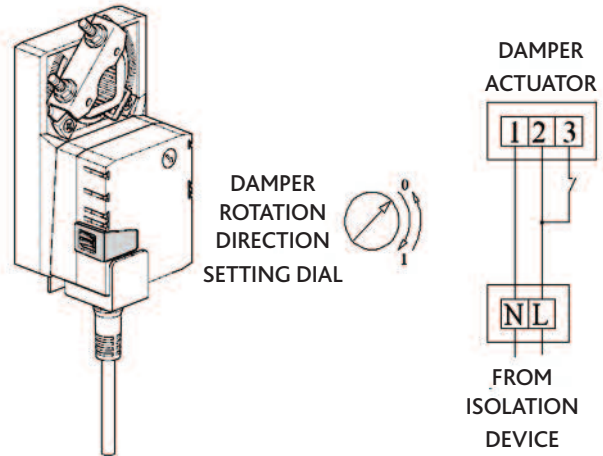

Fan Wiring – If HRCP* Controller Is Not Fitted Single Phase Motor

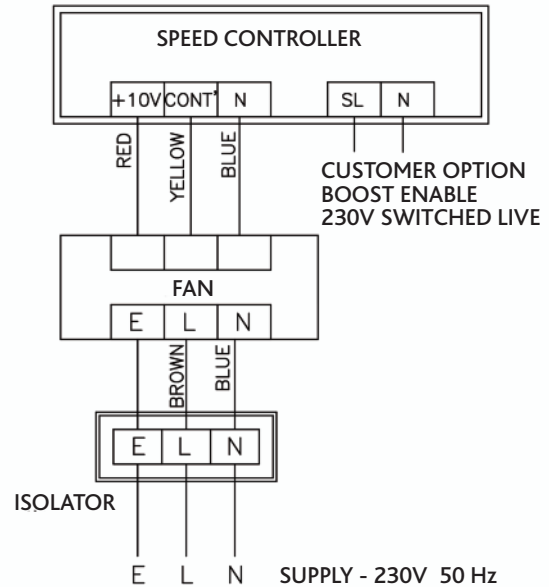

Three Phase Motor

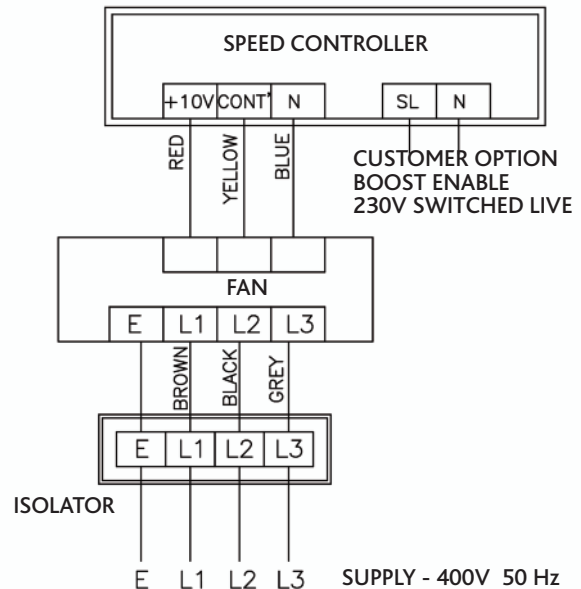

Electric Heater Battery

Introduction

Heaters of the sheathed element type provide a safe means of heating using electricity. The surface temperature of the elements is relatively low and they will not give an electric shock.

Heaters are suitable for either horizontal or vertical air-flow, though care should be taken to ensure the cutout is near the top of the duct.

An even flow of air across the elements **MUST** be maintained and the velocity should not fall below 1.75m/s. The heater should be positioned away from materials that may be damaged by direct heat.

Controls

A suitable control system should be installed which must include a timer to **keep the fan running for a period of 2 minutes after the heater has been switched off.**

A range of compatible control panels is available from AVT.

If a speed controller is being fitted, it **MUST NOT** allow the fan to be turned off independently of the control panel nor must it allow the air volume to **FALL BELOW** that stated on the heater nameplate.

Testing

Elements are tested prior to dispatch and are within a tolerance of +7.5W.

Elements stored in damp conditions may require drying out in order to achieve the correct insulation levels. Contact AVT in case of uncertainty.

Wiring Instructions

1. The electrical supply to the heater should be either 1ph or 3ph (with separate neutrals) - refer to nameplate for clarification.
2. Electrical cables should be of a high temperature, insulated type (i.e. silicone rubber or fibreglass) and be installed in accordance with current IEE wiring regulations.
3. The heater is fitted with a manual reset, thermal overload which will break the contacts when the duct temperature exceeds 130°C. This should be wired in series with the operating coil of the control circuit.
4. Ensure a suitable earth connection is made to the terminal provided.
5. The element studs are fitted with terminal pillars and care should be taken not to over tighten and cause damage to the elements.
6. Always fit an isolator for maintenance of the heater.

Component Layout

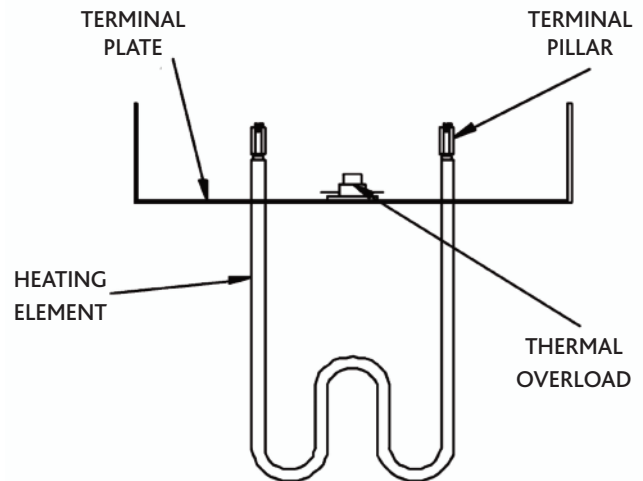

ELECTRIC HEATERS MUST BE WIRED AND INSTALLED IN ACCORDANCE WITH THE FOLLOWING DIAGRAMS AND INTRUCTIONS

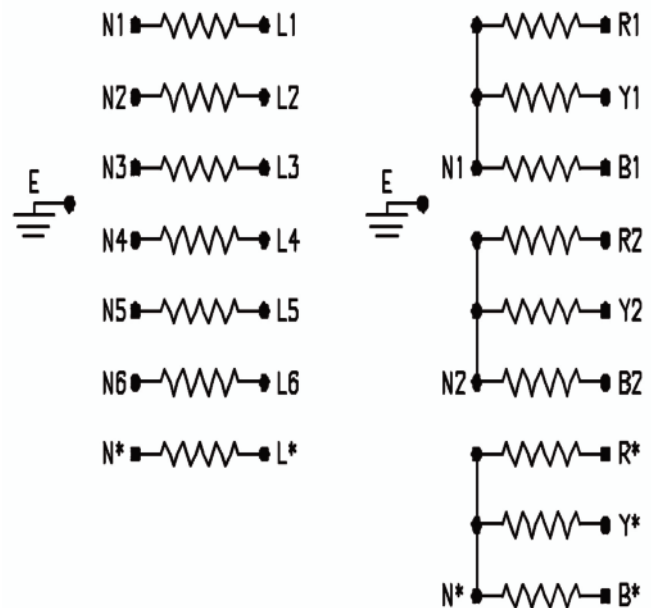

WHERE * = ANY NUMBER OF ADDITIONAL STEPS

LPHW Coil

Installation

Before installation check the coil for any minor fin damage and use a fin comb to reinstate the fins.

Check that the handing of the coil is correct for your application. The handing is determined whilst looking in the direction of airflow and relates to the position of the connections.

Install all coils with the tubes horizontal and level. This applies whether the airflow is horizontal or vertical. The reason is that this will allow for the most effective venting of the coil.

Coils are not to be used with the tubes vertical or inclined upwards unless this was agreed at the design stage.

Where coils are incorporated into ducting, it is important that they are properly installed.

Suitable sealing methods should be employed to prevent air bypassing the finned area of the coil.

The ducting should be fitted to the coil by removing the end covers (where fitted) and drilling through the coil platework and bolting into position. Care should be taken to protect the headers and return bends by using a piece of wood or sheet metal behind the platework being drilled. A suitable sealant should be used to seal the joints and when replacing the end covers.

Access should be provided to both ends of the coil, without the need to remove any of the external pipework, for the purpose of inspection, cleaning and maintenance.

Piping

Coils should be piped such that the water flowing into the coil is at the end where the air leaves the coil. This will give counterflow and the greatest heat transfer.

Coils should be piped according to any relevant local codes of practice.

Where threaded connections are supplied, the only approved method of jointing is by use of Boss white and hemp. The thread fitted to the coil is to be supported at all times whilst making joints. All external piping is to be supported independently from the coil.

Fluid filters are recommended.

Maintenance

Finned surfaces should be inspected regularly and cleaned if necessary.

Filters should be regularly changed to maintain constant air flows.

The coil should be inspected for signs of corrosion.

Circulating fluid should be kept free from impurities and corrosive elements.

Vent air from the coil on a regular basis. Automatic air vents are recommended.

Check all connections and tighten if necessary.

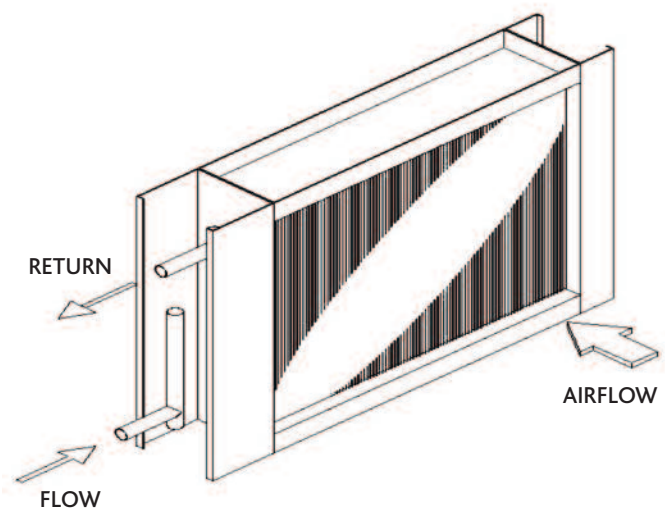

Air Vent Technology Ltd

56 Reith Way, Portway Industrial Estate

Andover, Hampshire, SP10 3TY

T: +44(0)1264 356415

E: sales@airventtechnology.co.uk

www.airventtechnology.co.uk

Part of the **Vectaire** Group of Companies