

# Tubular Framed Supply & Extract Units - STP/STR

## Installation, Operation and Maintenance Manual

### General Construction

Designed for **internal** applications, the **STP** range of air movers has a standard construction of a 30mm square aluminium frame fitted with 25mm thick double skinned panels.

Panels have an inner and outer skin of spangled galvanised sheet steel (GSS) and are lined with 45kg/m<sup>3</sup> density mineral wool slab.

Units are mounted on a 100mm high folded, galvanised sheet steel (GSS) channel base.

Designed for **external** applications, the **STR** range of air movers has a standard construction of a 30mm square aluminium frame fitted with 25mm thick double skinned panels.

Panels have an inner and outer skin of spangled galvanised sheet steel (GSS) and are lined with 45kg/m<sup>3</sup> density mineral wool slab.

The outer skin has a plastic coated finish.  
Colour: Grey – BS10A05

Units are mounted on a 100mm high folded, galvanised sheet steel (GSS) channel base.

Units are fitted with a pitched weather cap having a 100mm pitch.

### Inspection Upon Receipt Of Goods

Immediately upon receipt of any goods, a careful inspection should be undertaken to ensure neither damage nor missing parts. Particular attention should be paid to the fan impeller, motor shaft, anti-vibration mounts, flexible connection and casework.

In the event of such damage or loss having occurred, inform AVT (01264 356415) WITHIN 3 WORKING DAYS of the delivery date, giving the serial number which can be found on the name-plate. After this period we will be unable to entertain any claim for loss or damage.

### Installation

When installing our equipment, the following must be observed:

**Safety:** It is the responsibility of the installer to ensure that the installation complies with the legal regulations and the current **HEALTH AND SAFETY AT WORK ACT**.

**Ambient Temperatures:** The range of units covered by this manual are designed for use in an environment where the ambient air temperature is unlikely to exceed 40°C.

**Positioning Using Cranes:** Units being craned into position must be handled with care to avoid any damage. This applies particularly to weatherproof units, with overhanging lids and cowls, and also painted units. Where lifting lugs are provided these **MUST** be used. A spreader bar should be employed so as to prevent damage to the top of the unit. Strong points are provided on weather lids for straps.

**Mounting:** All centrifugal fan units **MUST** be mounted so that the fan shaft is horizontal. Failure to comply will result in fan failure.

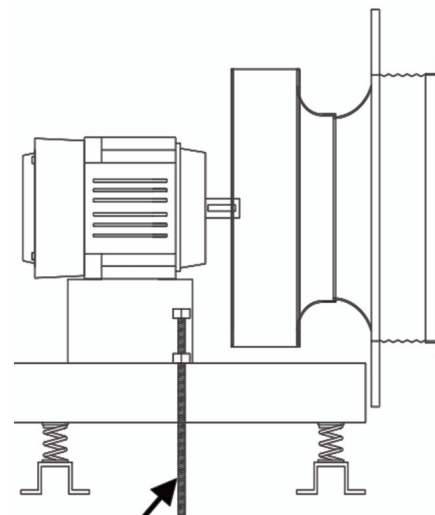

YELLOW TRANSIT BOLT

**Positioning/Assembly:** All units should be mounted on a completely flat base. Units supplied in sections should be bolted together using the self adhesive rubber tape and fasteners supplied. Once the unit is located in position the **YELLOW TRANSIT BOLT** securing the fan and motor assembly **MUST** be removed prior to startup.

Prior to starting the unit it is also important to ensure that the fans are free running, and should any components have moved during transit take care to ensure that they are realigned to allow correct operation/rotation. The same should be applied to any wiring looms which may have become unfastened; ensure that loose wiring is securely stowed away from any moving components. Inverter-driven plug fans are supplied as a balanced assembly and should not be disassembled.

**Duct Connections:** Adjoining ductwork should always be independently supported to avoid undue stress on the unit casing. Fans are internally isolated thus removing the need for external, flexible connections or anti-vibration mounts.

## Tubular Framed Supply & Extract Units - STP/STR Installation, Operation & Maintenance Manual

**Access** All units are designed with easily removable components for maintenance purposes. Sufficient room should be allowed adjacent to the unit to allow components to be withdrawn.

### Electrical Wiring

Electrical supply must be fully isolated before attempting any work on the unit.

All wiring should be carried out by a competent electrician and should comply fully with the current I.E.E. Wiring Regulations.

The electrical supply must be as stated on the nameplate.

When the wiring is complete, check for free and correct rotation of the fan impeller.

If a fan speed regulator is being used, study the wiring diagram and installation document.

### Vee Belt Drives

Before the unit is run, it is essential that the drive is checked to ensure correct alignment. The fan and motor shafts **MUST** be parallel. The motor pulley **MUST** be aligned with the fan pulley using a straight edge. Turn the fan shaft by hand to ensure free rotation. The belts should not be over tensioned as this may cause damage to the bearings and excessive wear on the belts. See the following diagrams for tensioning details. Belts should be re-tensioned after one month's running

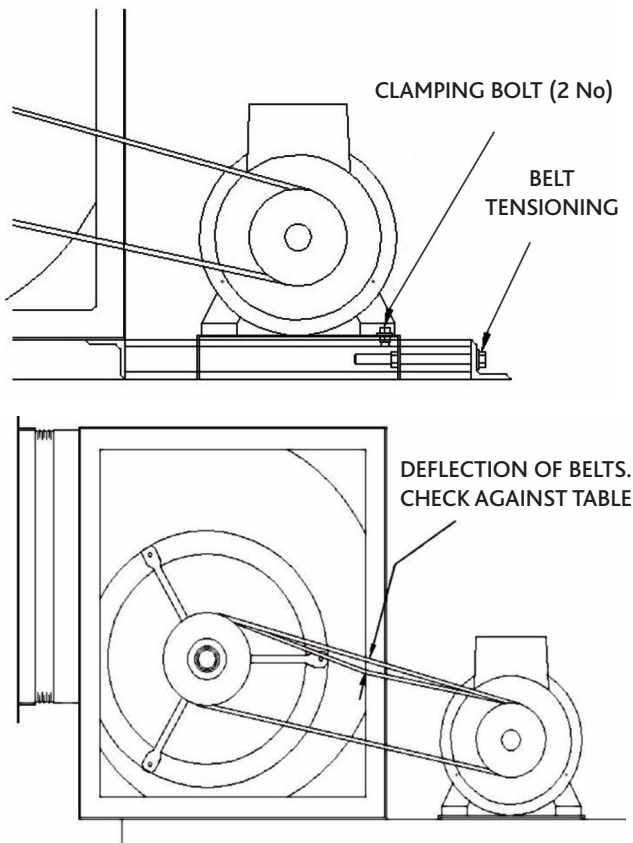

**To tighten belt:** Slacken off the two clamping bolts, turn the head of the belt tensioning stud until the required tension is achieved. Re-tighten the two clamping bolts.

Belts should be tensioned so the deflection of the belt should not exceed 16mm per 1 metre pulley centre distance, when a given force is applied to the belt (see chart below).

Belt	Small Pulley Diameter	Setting Force	
		Newton (N)	Kilograms (kgf)
SPZ	67 to 95	10 to 15	1.0 to 1.5
	100 to 140	15 to 20	1.5 to 2.0
SPA	100 to 132	20 to 27	2.0 to 2.7
	140 to 200	27 to 35	2.7 to 3.5
SPB	160 to 224	35 to 50	3.5 to 5.0
	236 to 315	50 to 65	5.1 to 6.5
SPC	224 to 355	60 to 90	6.1 to 9.0
	375 to 560	90 to 120	9.2 to 12.0

Belts should be inspected on a regular basis, checking for slackness or wear. Any slackness should be taken up as described on the previous page. Wear may be down to misaligned pulleys - this should be checked. Under normal conditions, the stretch within new belts will occur in the first few days of operation. New and used Vee Belts **MUST NOT** be mixed. Vee Belts of different types or brands **MUST NOT** be mixed. Always fit new belts of the same set.

### Heating and Cooling Coils

**Winter Conditions:** It is important that coils are protected against adverse weather during the winter period that may cause freezing and the danger of air being delivered at below 4.5°C. To protect heating coils, a thermostat should be installed down stream of the heater and set to 4.5°C. Its action should be to either stop the fan or close outside air dampers. Chilled water cooling coils fitted upstream of any heating coil should be drained to prevent freezing.

### Water Condition

It is recommended that a check is made on the water condition to ensure that any treatment to prevent corrosion or scaling has been applied. Information relating to this can be obtained from the relevant Water Authorities particulars which can be found in the Water Engineer Handbook yearly edition.

## Air Handling Units - Internal - SPE/EC Installation, Operation & Maintenance Manual

### Trapping

Correct trapping of the condensate line is essential to prevent flooding or liquid splashing back into the drain pan.

NEGATIVE PRESSURE DRAIN PAN    POSITIVE PRESSURE DRAIN PAN

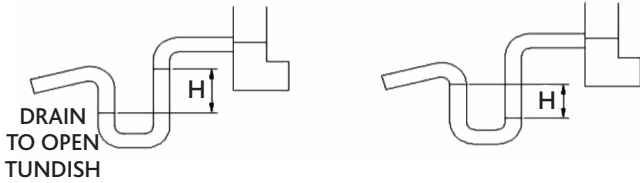

$DIM H = \text{Total Static Pressure mm Wg} + 12\text{mm minimum}$

### Water Coils

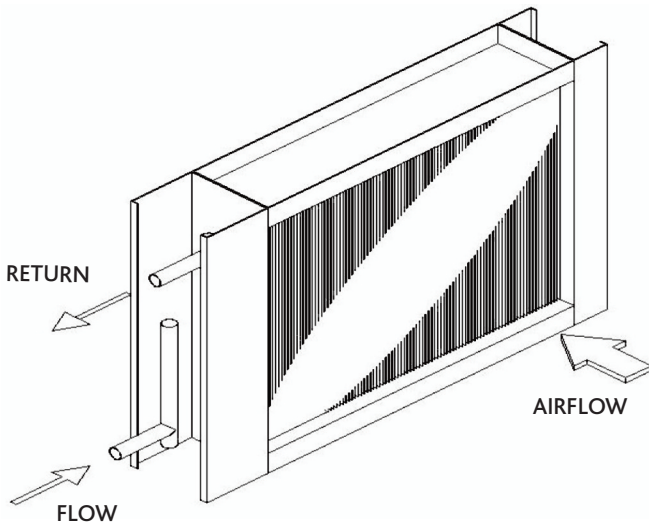

### Air Vents and Drain Plugs

These are not fitted to the coil but must be fitted in adjacent pipework. The air vent should be fitted at the highest point by the return connection and the drain below the flow connection.

The water flow connection is that on the air off side of the coil.

When the coil is mounted at a high point of the system it **MUST** be regularly vented, otherwise the coil may become air locked with a loss of duty.

### DX Coils

Must be fitted in accordance with accepted codes of practice for refrigeration systems. If fitted upstream of a heating coil, care must be taken to ensure that the air temperature does not fall below 0°C

### DX Coil

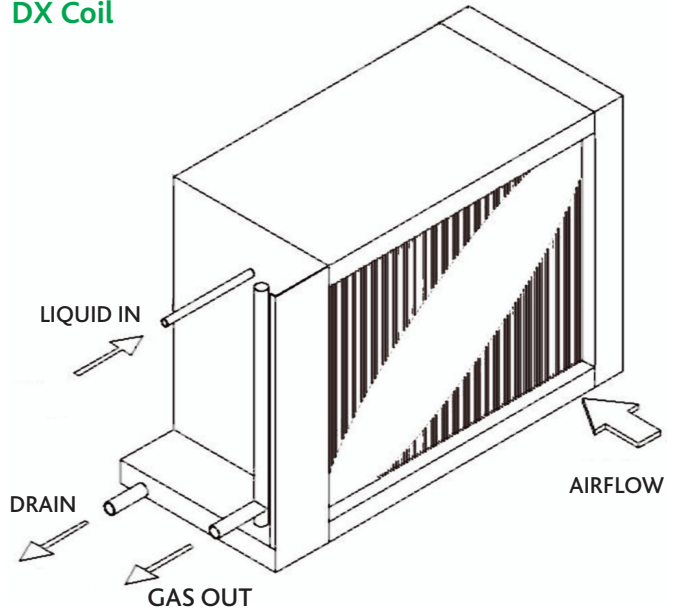

### Steam Coils

Steam coils are suitable for use with saturated steam up to 100psi.

The pipework **MUST** be arranged so as to provide adequate drain lines with a suitable strainer and drain trap.

All steam and drain lines **MUST** be suitably lagged. The steam supply is to be taken from the top of the steam main to avoid the introduction of moisture or air.

The pipe shall be arranged as to not interfere with the coil expansion.

If the pipe run is excessively long and prone to water logging, it **MUST** be fitted with a suitable trap just before the coil.

If the steam is being fed from a high pressure steam main, a pressure release valve fitted to the low side is required to prevent dangerous overheating of the air.

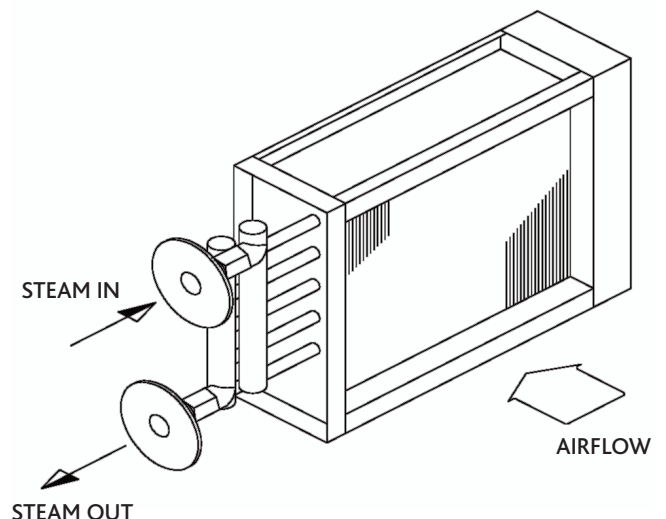

## Air Handling Units - Internal - SPE/EC Installation, Operation & Maintenance Manual

### Electric Heater Batteries

**REFER TO SEPARATE MANUAL ENTITLED  
INSTALLATION AND GENERAL NOTES FOR  
ELECTRIC HEATER BATTERIES.  
DOCUMENT REF: DO1001**

### Maintenance

**3 Monthly:** Filters should be inspected and if found to be heavily soiled, replaced.

If grease nipples are fitted to any fan/motor bearing or plumber block bearing, then inspect and recharge as necessary.

**6 Monthly:** The fan impeller should be carefully cleaned with a brush. This will prevent the impeller from becoming unduly dirty and become unbalanced.

Coils should be inspected to ensure no foreign material has accumulated on the fans. Should any be found, the fins can be cleaned using a soft brush and a mild detergent solution. Care **MUST** be taken not to damage the fins during the process. Should debris accumulate on the fins on a regular basis, check the filtration system to ensure correct operation.

Damper cogs, blades and frames should be cleaned and lubricated with a PTFE or silicone oil aerosol lubricant.

**12 Monthly:** The security and integrity of all fasteners should be checked. Particular attention should be paid to the impeller fixing onto the fan shaft.

If the unit has a paint finish this should be checked to ensure no deterioration and if necessary repainted with a suitable touch up paint.

Check A.V. mountings and flexible connections for signs of perishing or damage.

**NOTE:- UNDER NO CIRCUMSTANCES  
SHOULD ANY MAINTENANCE WORK BE  
ATTEMPTED WITHOUT FIRST COMPLETELY  
ISOLATING THE UNIT FROM ITS ELECTRICAL  
SUPPLY.**

### Spares

Spare parts or direct replacements are normally held in stock and are available for a period of up to 10 years from installation.

Any spare part can be ordered by contacting AVT (01264 356415) and quoting the unit serial number which can be found on the nameplate.

A complete list of recommended spares can be issued upon request.

## Air Vent Technology Ltd

56 Reith Way, Portway Industrial Estate

Andover, Hampshire, SP10 3TY

T: +44(0)1264 356415

E: sales@airventtechnology.co.uk

[www.airventtechnology.co.uk](http://www.airventtechnology.co.uk)

Part of the **Vectaire** Group of Companies